

Atlas Copco Air Dryers

FD7, FD16, FD30, FD40, FD60, FD80, FD100 and
FD120

Instruction Book

OWNERSHIP DATA

Unit type:
Motor type:
Delivery date:
Service Plan:

Owner's machine No.:
Unit serial No.:
Motor serial No.:
First start-up date:

Selected lubricants

Compressor:
Bearing grease type, electric motor:

Capacity:

Printed Matter Nos.

Atlas Copco instruction book:
Atlas Copco parts list:
Atlas Copco logbook:

Motor instruction book:
Motor parts list:

Local Atlas Copco Representative

Name:
Address:
Telephone: Contact persons: Service:
Telex: Parts:

SAFETY PRECAUTIONS

To be read attentively and acted accordingly before installing, operating or repairing the unit

These recommendations apply to machinery processing or consuming air or inert gas. Processing of any other gas requires additional safety precautions typical to the application which are not included herein.

In addition to normal safety rules which should be observed with stationary air compressors and equipment, the following safety directions and precautions are of special importance.

When operating this unit, the operator must employ safe working practices and observe all related local work safety requirements and ordinances.

The owner is responsible for maintaining the unit in a safe operating condition. Parts and accessories shall be replaced if unsuitable for safe operation.

Installation, operation, maintenance and repair shall only be performed by authorized, trained, competent personnel.

Normal ratings (pressures, temperatures, time settings, etc.) shall be durably marked.

Any modification on the compressor shall only be performed in agreement with Atlas Copco and under supervision of authorized, competent personnel.

If any statement in this book, especially with regard to safety, does not comply with local legislation, the stricter of the two shall apply.

These precautions are general and cover several machine types and equipment; hence some statements may not apply to the unit(s) described in this book.

connections shall be of correct size and suitable for the working pressure.

- Place the unit where the ambient air is as cool and clean as possible. If necessary, install a suction duct. Never obstruct the air inlet. Care shall be taken to minimize the entry of moisture with the inlet air.
- The aspirated air shall be free from flammable fumes or vapours, e.g. paint solvents, that can lead to internal fire or explosion.
- Air-cooled units shall be installed in such a way that an adequate flow of cooling air is available and that the exhausted air does not recirculate to the inlet.
- Arrange the air intake so that loose clothing of people cannot be sucked in.
- Ensure that the discharge pipe from the compressor to the aftercooler or air net is free to expand under heat and that it is not in contact with or close to flammable material.
- No external force may be exerted on the air outlet valve; the connected pipe must be free of strain.
- If remote control is installed, the unit shall bear an obvious sign reading:

DANGER: This machine is remotely controlled and may start without warning.

As a further safeguard, persons switching on remotely controlled units shall take adequate precautions to ensure that there is no one checking or working on the machine. To this end, a suitably worded notice shall be affixed to the start equipment.

Installation

Apart from general engineering practice in conformity with the local safety regulations, the following directives are specially stressed:

- A compressor shall be lifted only with adequate equipment in conformity with local safety rules.

Loose or pivoting parts shall be securely fastened before lifting. It is strictly forbidden to dwell or stay in the risk zone under a lifted load. Lifting acceleration and retardation shall be kept within safe limits.

- Any blanking flanges, plugs, caps and desiccant bags shall be removed before connecting up the pipes. Distribution pipes and

- On units with automatic start-stop system, a sign stating "**This machine may start without warning**" shall be attached near the instrument panel.
- In multiple compressor systems manual valves shall be installed to isolate each compressor. Non-return valves (check valves) shall not be relied upon for isolating pressure systems.
- Never remove or tamper with the safety devices, guards or insulations fitted on the unit. Every pressure vessel or auxiliary installed outside

Instruction book for
Air dryers

**FD7, FD16, FD30, FD40,
FD60, FD80, FD100 and
FD120**

From following serial numbers onwards:

FD7: AIQ-121 314

FD80: AIQ-152 000

FD16: AIQ-121 319

FD100: AIQ-152 500

FD30, -40, -60: AIQ-128 737

FD120: AIQ-153 000

Registration code

Collection: APC FD

Tab: 38

Sequence: 990

Replaces

No. 2920 1339 01

No. 2920 1339 02

1998-01

This instruction book meets the requirements for instructions specified by the machinery directive 89/392/EEC and is valid for CE as well as non-CE labelled machines



Industrial Air Division - B-2610 Wilrijk - Belgium



* 2 9 2 0 1 3 3 9 0 2 *

This instruction book describes how to handle and operate the subject machine(s) to ensure safe operation, optimum working economy and long service life.

Read this book before putting the machine into operation to ensure correct handling, operation and proper maintenance from the beginning. The maintenance schedule contains a summary of the measures for keeping the dryer in good repair. The maintenance procedures are simple but must be carried out regularly.

Keep the book available for the operator(s) and make sure that the dryer is operated and that the maintenance actions are carried out according to the instructions. Record all operating data, maintenance work effected, etc. in an operator's logbook available from Atlas Copco. Follow all applicable safety precautions, amongst others those mentioned in this book.

Repair operations should be performed by trained personnel from Atlas Copco who can also be contacted if any further information is desired.

In all correspondence always mention the dryer type and the complete serial number, shown on the data plate.

For all specific data not mentioned in the text, consult sections "Maintenance" and "Principal data".

The company reserves the right to make changes without prior notice.

Contents

	Page		Page
1 Leading particulars	3	4 Maintenance	14
1.1 General description	3		
1.2 Air circuit	3	5 Settings	14
1.3 Refrigeration circuit	3		
1.4 Automatic regulation system	3	6 Problem solving	14
1.5 Electrical system	5		
2 Installation	8	7 Principal data	15
2.1 Dimension drawings	8	7.1 Limitations/nominal conditions	15
2.2 Installation proposal	11	7.2 Specific data FD7 and FD16	15
2.3 Installation instructions	12	7.3 Specific data FD30, FD40 and FD60	16
2.4 Pictographs	13	7.4 Specific data FD80, FD100 and FD120	16
3 Operating instructions	13	8 Conversion list of SI units into British units	16
3.1 Starting	13		
3.2 During operation	13		
3.3 Stopping	13		

1 LEADING PARTICULARS

1.1 General description

The FD air dryers remove moisture from compressed air by cooling the air to near freezing point. This causes water to condense. The condensate is automatically drained. The air is warmed up before leaving the dryer.

1.2 Air circuit (Figs. 2)

Compressed air enters heat exchanger (13) and is cooled by the outgoing, cold, dried air. Water in the incoming air starts to condense. The air then flows through heat exchanger/evaporator (11) where the refrigerant evaporates causing the air to be further cooled to close to the evaporating temperature of the refrigerant. More water in the air condenses. The cold air then flows through separator (3) where all the condensate is separated from the air. The condensate collects in condensate trap (4) and is automatically drained. The cold, dried air flows through heat exchanger (13), where it is warmed up by the incoming air to approx. 10°C (18°F) below the incoming air temperature. Condensation in the air net cannot occur unless the air is cooled to below the pressure dewpoint indicated by gauge (1).

1.3 Refrigeration circuit (Figs. 2)

Compressor (M1) delivers hot, high-pressure refrigerant gas which flows through condenser (9) where most of the refrigerant condenses.

The liquid flows through liquid refrigerant dryer/filter (12) to capillary tube (7). The refrigerant leaves the capillary tube at evaporating pressure.

The refrigerant enters evaporator (11) where it withdraws heat from the compressed air by further evaporation at constant pressure. The heated refrigerant leaves the evaporator and is sucked in by the compressor.

1.4 Automatic regulation system (Figs. 2)

The condenser pressure must be kept as constant as possible to obtain stable operation, therefore, fan control switch (S3) stops and starts the cooling fan.

When, at partial or no load, the evaporator pressure drops to 2.25 bar(e), the by-pass regulator opens and hot, high pressure gas is fed to the evaporator circuit to prevent the evaporator pressure from dropping any further.

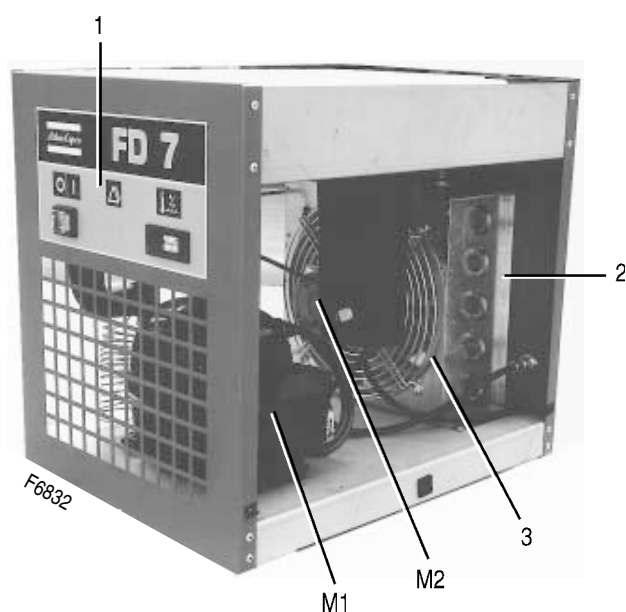

- M1. Refrigerant compressor
- M2. Condenser fan motor
- 1. Control panel
- 2. Condenser
- 3. Fan

Fig. 1. General view of FD7

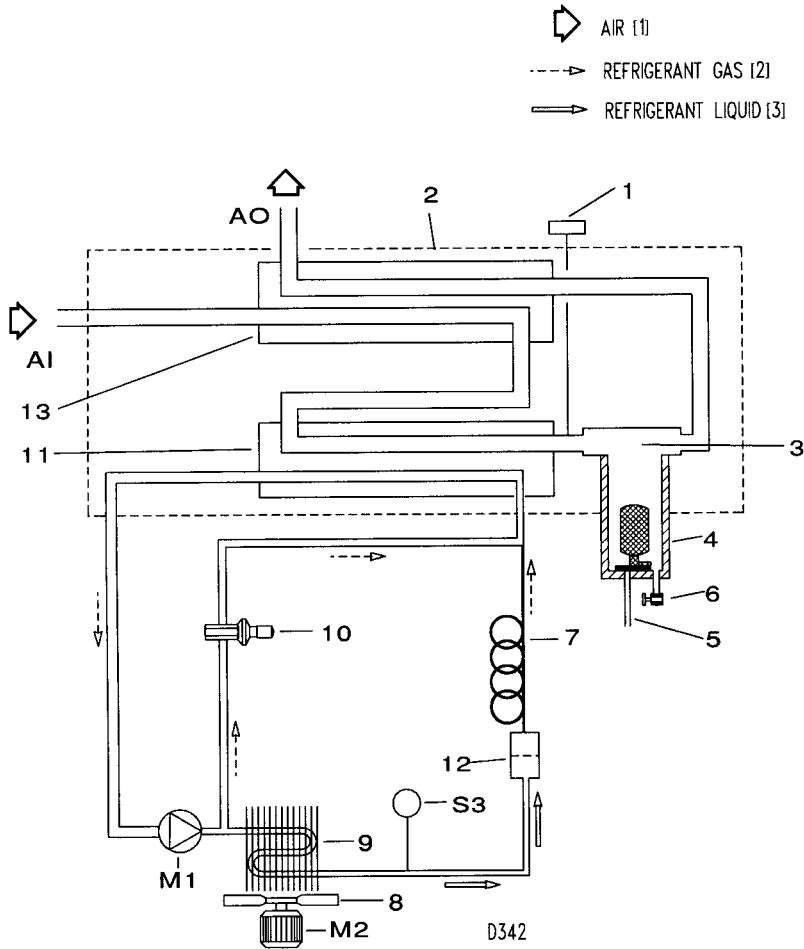

- AI. Wet air inlet
- AO. Dry air outlet
- M1. Refrigerant compressor
- M2. Condenser fan motor
- S3. Fan control switch
- 1. Pressure dewpoint gauge
- 2. Insulating block
- 3. Condensate separator
- 4. Condensate trap
- 5. Automatic condensate drain hose
- 6. Manual condensate drain valve
- 7. Capillary tube
- 8. Condenser cooling fan
- 9. Refrigerant condenser
- 10. Hot gas by-pass valve
- 11. Air/refrigerant heat exchanger/evaporator
- 12. Liquid refrigerant dryer/filter
- 13. Air/air heat exchanger
- 14. Accumulator (not for FD7 and FD16)

Figs. 2. Air and refrigerant flow diagrams

Fig. 2a. Air and refrigerant flow diagram of FD7 and FD16

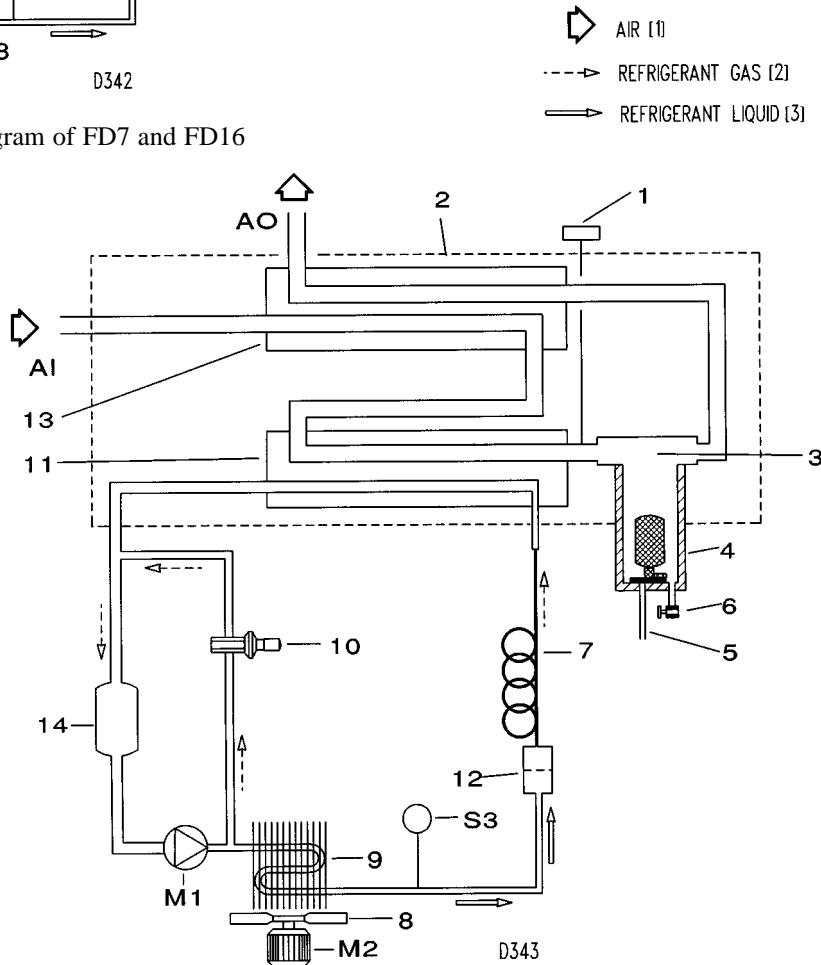

Fig. 2b. Air and refrigerant flow diagram of FD30, FD40 and FD60

1.5 Electrical system (Figs. 3)

FD dryers are single-phase units.

Fan control switch (S3) starts fan motor (M2) as soon as the condenser pressure reaches the upper set point of the switch and will stop the fan motor when the condenser pressure decreases to its lower set point.

The compressor motor has a built-in thermic protection. If the compressor motor stops without apparent reason, it will probably be the thermic protection which has tripped. In such case, the compressor will restart when the motor windings have cooled down, which may take up to 2 hours.

An electronic thermostat (Fig. 11) with display and alarm functions is available as an option. Display (3) shows the pressure dewpoint. The set point value, i.e. the pressure dewpoint at which the alarm indicator lamp (H2-Fig. 3) lights up, can be checked by pressing key (5); the value will blink for

approx. 5 seconds on the display. The differential value, i.e. the temperature difference between alarm on and alarm off, can be checked by pressing key (4); the value will blink on the display for approx. 5 seconds.

Altering the set point value (indicated "L1")

- Press key (5); the current value blinks on the display.
- Press the up (1) or down (2) key until the desired value is reached.
- To store the new value, press key (5) or wait a few seconds.

Altering the differential value (indicated "HY1")

- Press key (4); the current value blinks on the display.
- Press the up (1) or down (2) key until the desired value is reached.
- Press key (5) or wait a few seconds to store the new value.

If the temperature increases above the preset value, alarm indicator lamp (H2-Fig. 3) will light up.

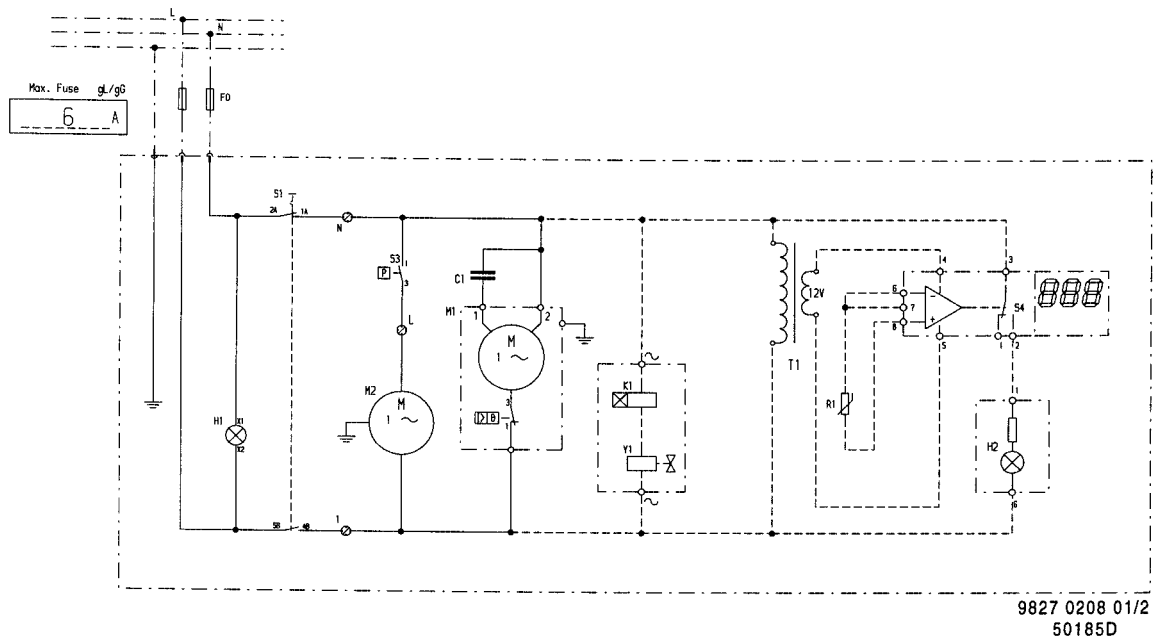

9827 0208 01/2
50185D

(1) TYPE	(2) VOLTAGE	(3) FREQUENCY	(4) Compr. motor		(5) Fan motor		I _t (A)
			P _e (kW)	input	P (kW)	input	
FD7	230V	50Hz	0.14	0.945	0.065	0.42	1.365
FD16	230V	50Hz	0.21	1.350	0.065	0.42	1.770
FD16	220V	60Hz	0.24	1.55	0.053	0.34	1.69
FD16	115V	60Hz	0.24	2.860	0.058	0.71	3.570

Fig. 3a. Electrical diagram of FD7 and FD16

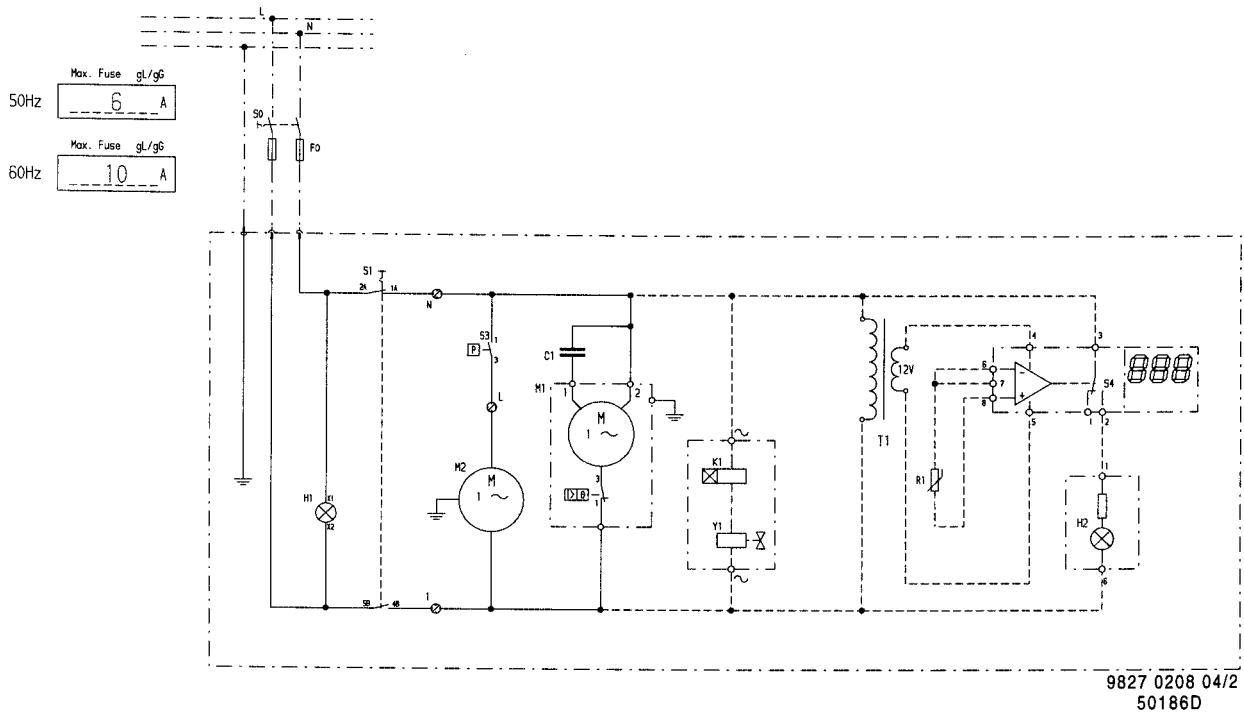

(1) TYPE	(2) VOLTAGE	(3) FREQUENCY	(4) Compr. motor		(5) Fan motor		It (A)
			P (KW)	In (A)	P (KW)	In (A)	
FD30	230V	50Hz	0.40	2.48	0.070	0.48	2.96
FD30	115V	60Hz	0.63	6.65	0.065	0.85	7.50
FD30	230V	60Hz	0.60	3.70	0.062	0.42	4.12
FD40	230V	50Hz	0.47	2.84	0.070	0.48	3.32

Fig. 3b. Electrical diagram of FD30 and FD40 50 Hz

- | | | |
|--|---|---|
| C1. Start capacitor | M1. Compressor motor | S1. Button, ON-OFF |
| F0. Main fuses, local installation (customer's installation) | M2. Fan motor | S3. Fan control switch |
| H1. Indicator lamp, VOLTAGE ON | R1. Temperature sensor, dewpoint (optional) | S4. Electronic thermostat with display (optional) |
| H2. Indicator lamp, DEWPOINT ALARM (optional) | S0. Main switch (customer's installation) | T1. Transformer (optional) |
| K1. Timer (optional) | | Y1. Solenoid valve, interval drain (optional) |

Figs. 3. Electrical diagrams

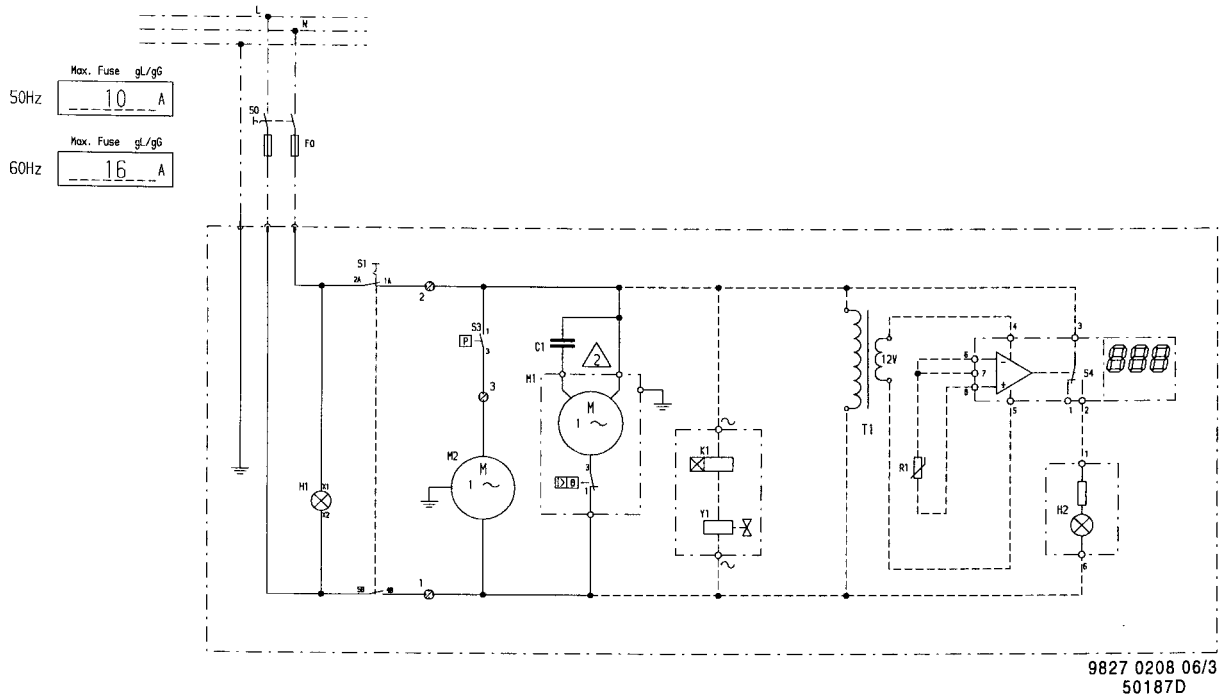

(1) TYPE	(2) VOLTAGE	(3) FREQUENCY	(4) Compr. motor M1		(5) Fan motor M2		I t (A)
			Pe (kW)	In (A)	P (kW)	In (A)	
FD40	115V	60Hz	0.94	11.8	0.065	0.85	12.65
FD40	230V	60Hz	0.86	5.8	0.062	0.42	6.22
FD60	230V	50Hz	0.79	4.98	0.070	0.48	5.46
FD60	115V	60Hz	0.94	11.8	0.065	0.85	12.65
FD60	230V	60Hz	0.86	5.8	0.062	0.42	6.22

Fig. 3c. Electrical diagram of FD40 60 Hz and FD60

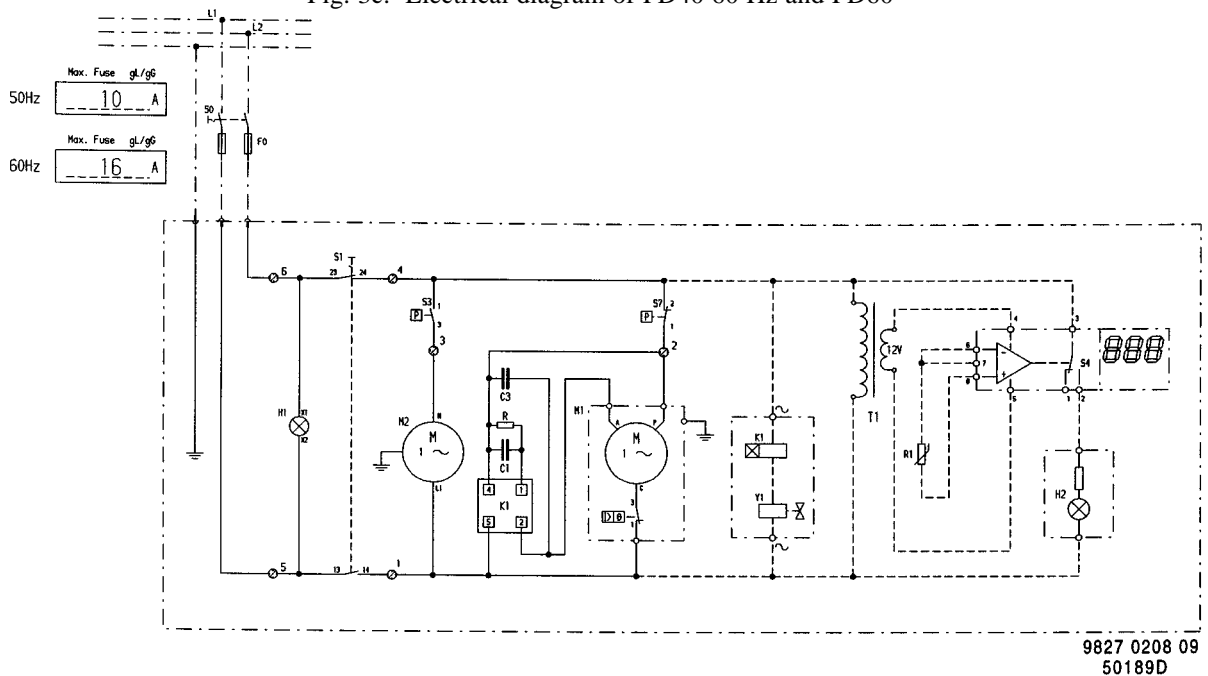

(1) TYPE	(2) VOLTAGE	(3) FREQUENCY	(4) Compr. motor M1		(5) Fan motor M2		I t (A)
			Pe (kW)	In (A)	P (kW)	In (A)	
FD80	230V	50Hz	0.92	4.2	0.14	0.60	4.8
FD80	230V	60Hz	1.18	6.0	0.17	0.70	6.7
FD100	230V	50Hz	1.10	5.2	0.14	0.60	5.8
FD100	230V	60Hz	1.38	6.9	0.17	0.70	7.6
FD120	230V	50Hz	1.26	5.9	0.14	0.60	6.5
FD120	230V	60Hz	1.90	9.3	0.17	0.70	10.0

Fig. 3d. Electrical diagram of FD80, FD100 and FD120

2 INSTALLATION

2.1 Dimension drawings (Figs. 4)

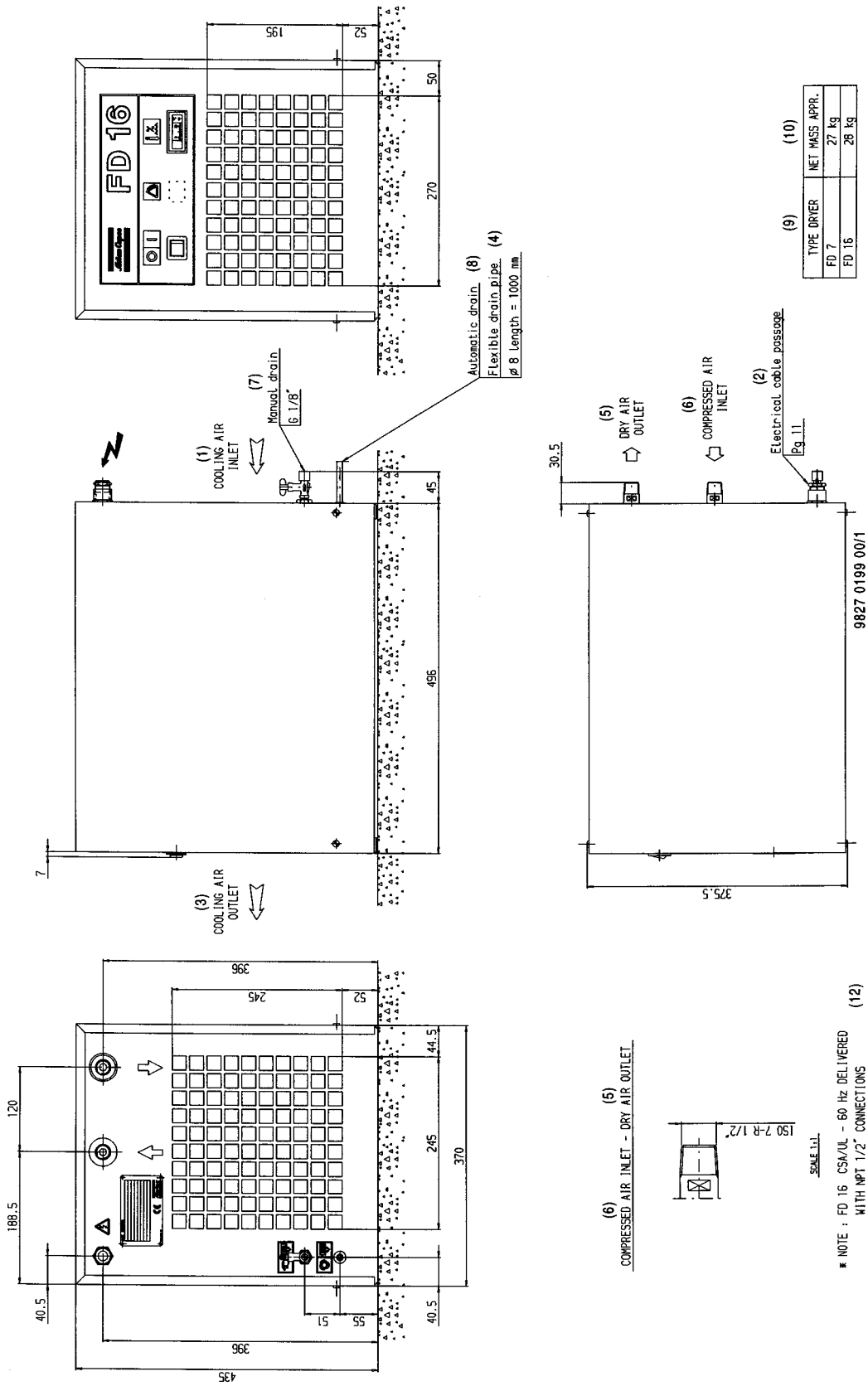

Fig. 4a. Dimension drawing of FD7/16

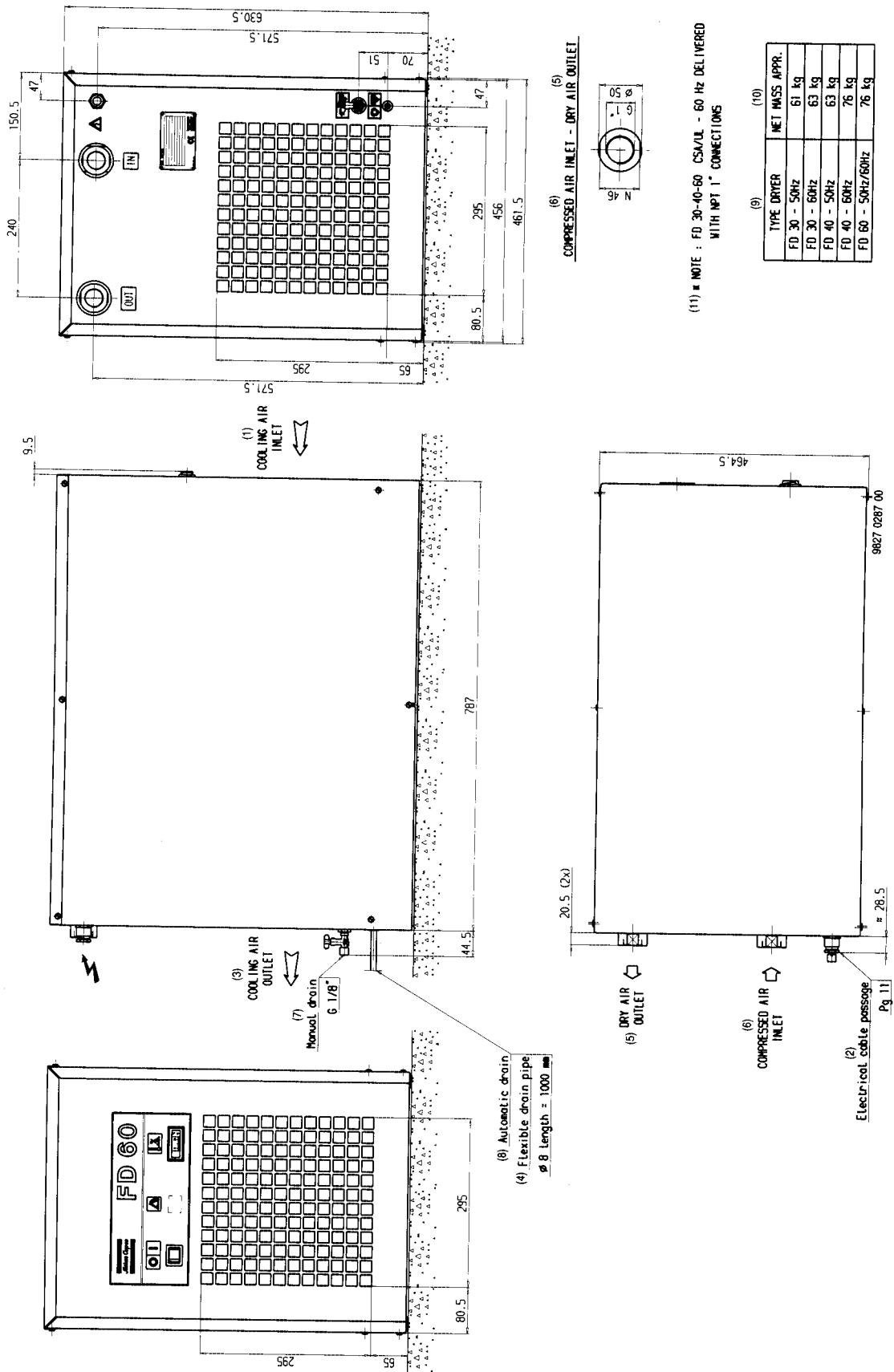

Fig. 4b. Dimension drawing of FD30, FD40 and FD60

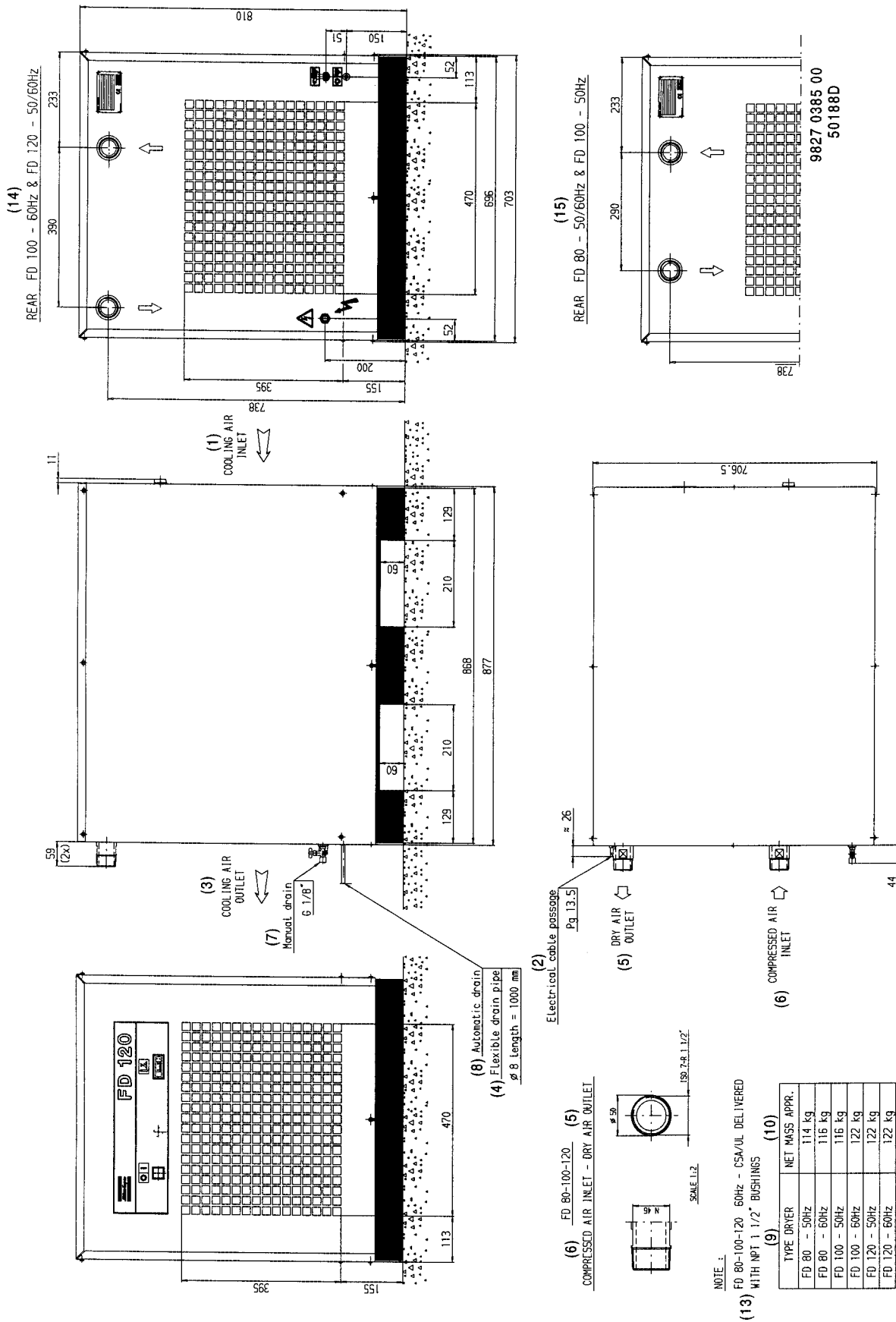
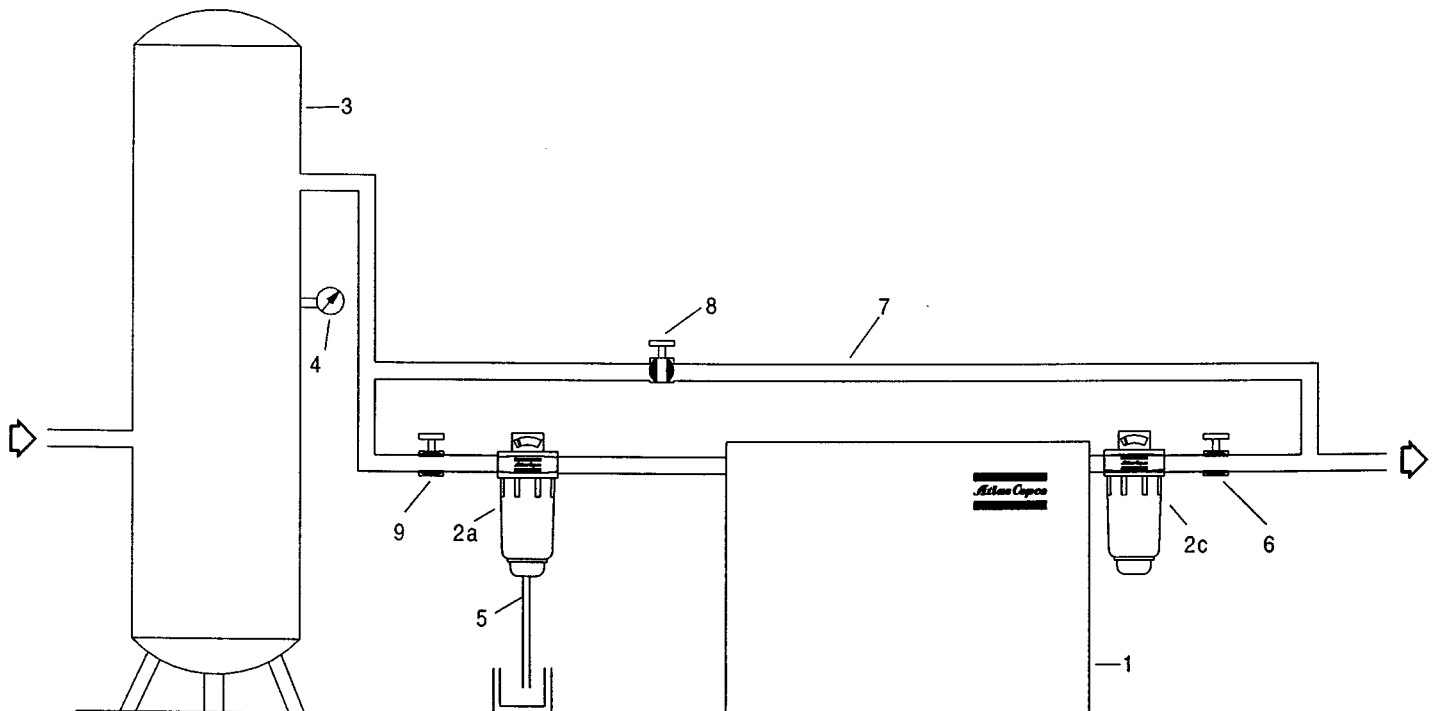

Fig. 4c. Dimension drawing of FD80, FD100 and FD120

Figs. 4. Dimension drawings

2.2 Installation proposal (Fig. 5)



D0527_2

- | | | |
|---------------------------------------|---------------------------------------|----------------------|
| 1. FD dryer | 3. Air receiver with condensate drain | 7. By-pass system |
| 2a. DD-type general-purpose prefilter | 4. Pressure gauge | 8. By-pass valve |
| 2c. PD-type afterfilter | 5. Drain pipes | 9. Dryer inlet valve |
| | 6. Dryer outlet valve | |

Fig. 5. Installation proposal

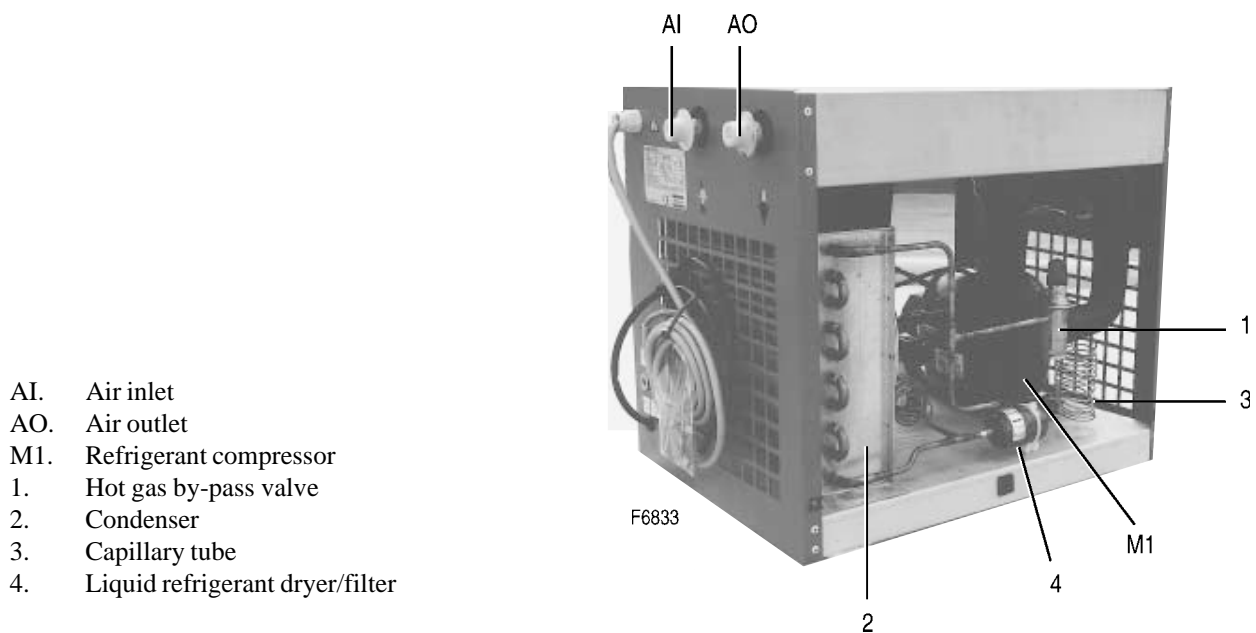
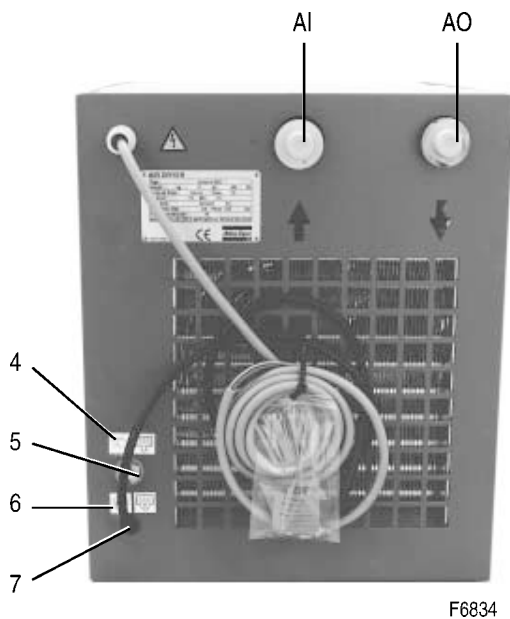

Fig. 6. Side view

2.3 Installation instructions

1. Install the dryer where the ambient air is as clean as possible and where the temperature of the air will never exceed the limits (see section 7). Keep the ventilation gratings of the dryer free.
If necessary, take action to avoid external influences (wind, draughts, etc.) through the ventilation gratings of the dryer, as they may disturb the cooling air flow.
2. Connect the compressed air lines to the marked inlet and outlet pipes of the dryer (Figs. 6 and 7). Provide an air inlet valve and outlet valve. If a by-pass pipe and valve are installed, the dryer can be serviced while by-passing the dryer.

3. Fit manual condensate drain valve (5-Fig. 7).
Lay out the condensate drain hoses via a funnel towards a drain collector to allow visual inspection. The hoses must slope downwards. For draining of pure condensate, install an oil/water separator; consult Atlas Copco.
If the condensate drain has been led down outside the compressor room where it may be exposed to freezing temperatures, it must be insulated.
4. A sticker dealing in short with the operating instructions and explaining the pictographs is delivered with the literature set. Affix the sticker next to the control panel. Make yourself familiar with the instructions and pictographs explained.
5. Fit the electric plug to the voltage supply cable. Plug in the dryer.



- AI. Air inlet
- AO. Air outlet
- 4. Pictograph, manual condensate drain
- 5. Manual condensate drain valve
- 6. Pictograph, automatic condensate drain
- 7. Automatic condensate drain

Fig. 7. Rear view

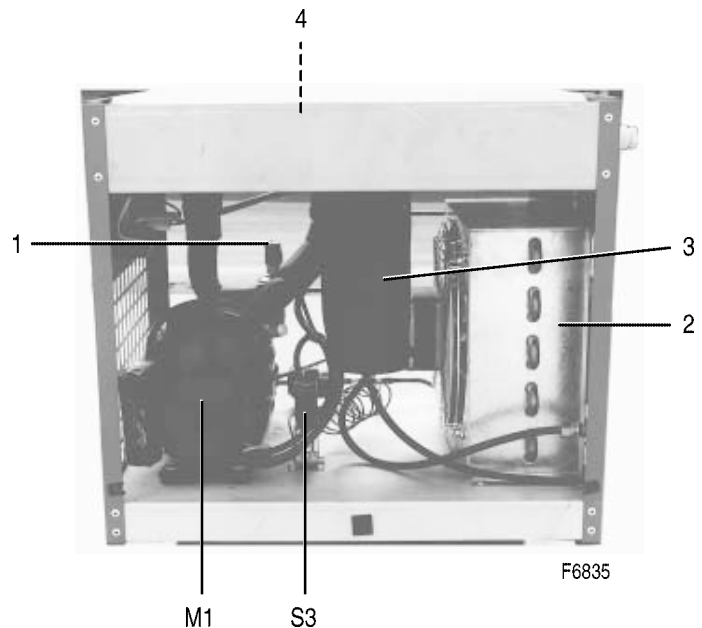

- M1. Refrigerant compressor
- S3. Fan control switch
- 1. Hot gas by-pass valve
- 2. Condenser
- 3. Condensate trap
- 4. Heat exchangers

Fig. 8. Side view

2.4 Pictographs (Fig. 9)

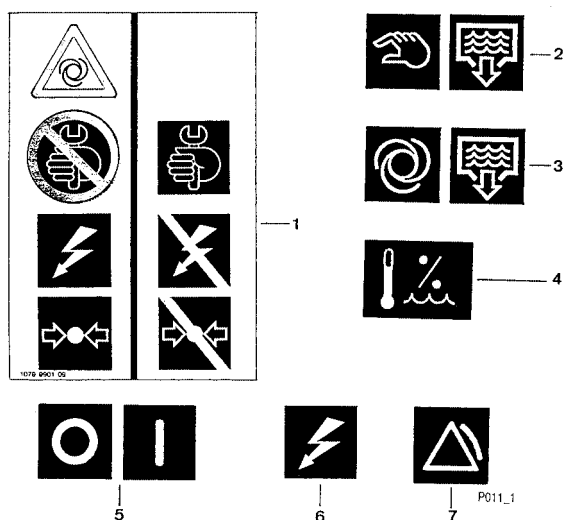

- | | |
|---|--|
| <ol style="list-style-type: none"> 1. Switch off and depressurize the dryer before starting maintenance or repairs 2. Manual condensate drain | <ol style="list-style-type: none"> 3. Automatic condensate drain 4. Pressure dewpoint 5. Dryer on-off 6. Voltage on 7. Dewpoint alarm |
|---|--|

Fig. 9. Pictographs

3 OPERATING INSTRUCTIONS

Safety precautions

The operator must apply all relevant safety precautions, including those mentioned in this book.

Altitude operation

Consult Atlas Copco if operating above 3000 m.

3.1 Starting (Fig. 10)

1. If installed, close the dryer by-pass valve.
2. Press on-off button (S1).
3. Open the dryer air inlet valve (customer's installation).
4. Approx. 5 minutes later, open the dryer air outlet valve (customer's installation).
5. Approx. 10 minutes later, the nominal dewpoint will be reached.

3.2 During operation

Regularly check:

1. Pressure dewpoint indicator (1-Fig. 10). 1)
2. That condensate is discharged (7-Fig. 7). The amount depends on the operating conditions.
3. Regularly open manual drain valve (5-Fig. 7) for approx. 10 seconds to discharge condensate and possible impurities.

3.3 Stopping (Fig. 10)

1. Close the dryer inlet and outlet valves (customer's installation).
2. Press on-off button (S1). The dryer stops. Voltage on lamp (H1) remains alight.

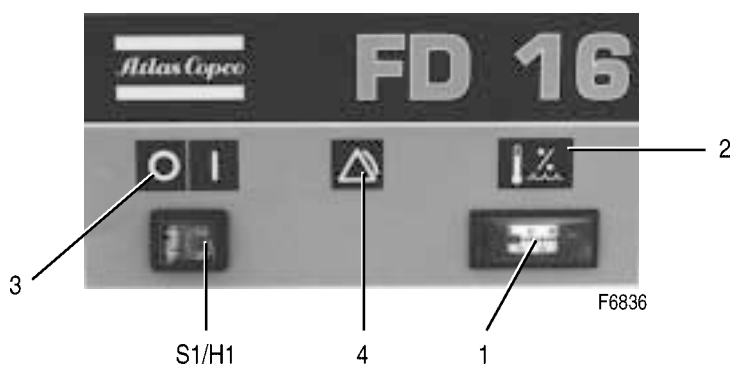

- | | |
|-----|-------------------------------|
| H1. | Indicator lamp, VOLTAGE ON |
| S1. | Button, ON-OFF |
| 1. | Pressure dewpoint indicator |
| 2. | Pictograph, pressure dewpoint |
| 3. | Pictograph, dryer on-off |
| 4. | Pictograph, dewpoint alarm |

Fig. 10. Control panel

1) The pressure dewpoint will deviate from nominal if the air inlet conditions or volume flow differ from nominal.

4 MAINTENANCE

Cooling dryers of FD type contain refrigerant HFC.

Safety precautions

When handling refrigerant R134a or R404a, all applicable safety precautions must be observed. The following points are stressed:

- Contact of refrigerant with the skin will cause freezing. Special gloves must be worn and in case of contact, the skin should be rinsed with water. On no account may clothing be removed.
- Fluid refrigerant will also cause freezing of the eyes; therefore, **safety glasses** are a must.
- Refrigerant R134a or R404a is poisonous. Do not inhale refrigerant vapours. Check that the working area is adequately ventilated.

Local legislation may impose that:

- work in the refrigerant circuit of the cooling dryer or on any equipment which influences its function should according to the law be executed by an **authorized control body**.
- the installation should according to the law be checked once a year by an **authorized control body**.

General

- Keep the dryer clean.
- Brush or blow off the finned surface of condenser (2-Fig. 1) regularly.
- Once every six months inspect and clean the inner components of condensate trap (3-Fig. 8).

5 SETTINGS

The regulating and safety devices are factory-adjusted to obtain optimum performance of the dryer. Do not alter the setting of any of the devices.

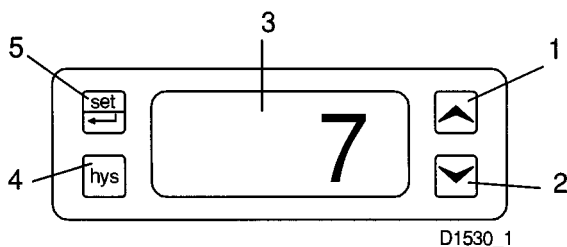

1. Key, value up
2. Key, value down
3. Display
4. Key, differential value
5. Key, set point of maximum pressure dewpoint

Fig. 11. Detail of electronic dewpoint indicator (optional)

6 PROBLEM SOLVING (Figs. 2)

1. Pressure dewpoint too high

- a. Air inlet temperature too high
 - a. Check and correct; if necessary, install a pre-cooler
 - b. Ambient temperature too high
 - b. Check and correct; if necessary, draw cooling air via a duct from a cooler place or relocate dryer
 - c. Air inlet pressure too low
 - c. Increase inlet pressure
 - d. Dryer capacity exceeded
 - d. Reduce air flow
 - e. Shortage of refrigerant
 - e. Have circuit checked for leaks and recharged
 - f. Refrigerant compressor (M1) does not run
 - f. See 3
 - g. Evaporator pressure too high
 - g. See 6
 - h. Condenser pressure too high
 - h. See 2

2. Condenser pressure too high or too low

- a. Fan control switch (S3) out of order
 - a. Replace
 - b. Fan or fan motor out of order
 - b. Check fan/fan motor
 - c. Ambient temperature too high
 - c. Check and correct; if necessary, draw cooling air via a duct from a cooler place or relocate dryer
 - d. Condenser externally clogged
 - d. Clean condenser

3. Compressor stops or does not start

- a. Electric power supply to compressor is interrupted
 - a. Check and correct as necessary
 - b. Thermic protection of refrigerant compressor motor (M1) has tripped
 - b. Motor will restart when motor windings have cooled down

4. Condensate trap remains inoperative

- a. Automatic drain system clogged
 - a. Flush the assembly by opening manual drain valve. Have system inspected

5. Condensate trap continuously discharges air and water

- a. Automatic drain system out of order
 - a. Have system checked

6. Evaporator pressure is too high or too low at unload

- a. Hot gas by-pass valve incorrectly set or out of order
 - a. Have hot gas by-pass valve adjusted
 - b. Condenser pressure too high or too low
 - b. See 2
 - c. Shortage of refrigerant
 - c. Have circuit checked for leaks and recharged

7 PRINCIPAL DATA

7.1 Limitations/nominal conditions

		50 Hz	60 Hz
Nominal conditions			
Compressed air inlet pressure			
- HP versions	bar(e)	20	20
- Others	bar(e)	7	7
Compressed air inlet temperature			
	°C	35	38
Ambient temperature			
	°C	25	38
Inlet relative vapour pressure			
		1	1
Pressure dewpoint			
	°C	3	4
Cooling air inlet temperature			
	°C	25	38
Limitations			
Maximum compressed air inlet pressure			
- HP versions	bar(e)	20	20
- Others	bar(e)	13	13
Min.-max. ambient air temperature			
	°C	0-45	0-45
Min.-max. compressed air inlet temperature			
	°C	0-55	0-55

7.2 Specific data FD7 and FD16 1)

			FD7	FD16	FD7HP	FD16HP
Volume flow at dryer inlet at nominal conditions						
	50 Hz	l/s	7	16	10	23
	60 Hz	l/s	--	16	--	21
Pressure drop through dryer at nominal conditions, approx.						
	50 Hz	bar	0.10	0.17	0.08	0.13
	60 Hz	bar	--	0.17	--	0.11
Electric power input						
	50 Hz	kW	0.22	0.28	0.26	0.34
	60 Hz	kW	--	0.35	--	0.39
Refrigerant						
Tetrafluoroethane CH ₂ FCF ₃						
Total charge, approx.	50 Hz	kg	0.205	0.22	0.205	0.22
	60 Hz	kg	--	0.23	--	0.23

1) At nominal conditions

7.3 Specific data FD30, FD40 and FD60 1)

			FD30	FD40	FD60	FD30HP	FD40HP
Volume flow at dryer inlet at nominal conditions	50 Hz	l/s	30	40	60	43	57
	60 Hz	l/s	34	50	62	44	--
Pressure drop through dryer at nominal conditions, approx.	50 Hz	bar	0.14	0.20	0.19	0.11	0.16
	60 Hz	bar	0.14	0.11	0.19	0.09	--
Electric power input	50 Hz	kW	0.47	0.54	0.86	0.56	0.65
	60 Hz	kW	0.70	1.01	1.01	0.80	--
Refrigerant							
Tetrafluoroethane CH ₂ FCF ₃			R134a	R134a	R134a	R134a	R134a
Total charge, approx.	50 Hz	kg	0.72	0.74	1.20	0.72	0.74
	60 Hz	kg	0.74	1.20	1.20	0.74	--

7.4 Specific data FD80, FD100 and FD120 1)

			FD80	FD100	FD120
Volume flow at dryer inlet at nominal conditions	50 Hz	l/s	80	100	120
	60 Hz	l/s	90	108	132
Pressure drop through dryer at nominal conditions, approx. . .	50 Hz	bar	0.15	0.20	0.15
	60 Hz	bar	0.15	0.13	0.15
Electric power input	50 Hz	kW	1.10	1.30	1.40
	60 Hz	kW	1.40	1.60	2.10
Refrigerant					
Tetrafluoroethane CH ₂ FCF ₃			R404a	R404a	R404a
Total charge, approx.	50 Hz	kg	0.80	1.00	1.10
	60 Hz	kg	1.00	1.10	1.10

8 CONVERSION LIST OF SI UNITS INTO BRITISH UNITS

1 bar = 14.504 psi	1 kW = 1.341 hp (UK and US)	1 l = 0.035 cu.ft	1 mbar = 0.401 in wc
1 g = 0.035 oz	1 l = 0.264 US gal	1 m = 3.281 ft	1 N = 0.225 lbf
1 kg = 2.205 lb	1 l = 0.220 Imp gal (UK)	1 mm = 0.039 in	1 Nm = 0.738 lbf.ft
1 km/h = 0.621 mile/h		1 m ³ /min = 35.315 cfm	x °C = (32 + 1.8x) °F 2)

1) At nominal conditions
 2) A temperature difference of 1°C = a temperature difference of 1.8°F

SAFETY PRECAUTIONS (continued)

the unit to contain air above atmospheric pressure shall be protected by a pressure-relieving device or devices as required.

13. Pipework or other parts with a temperature in excess of 80°C (175°F) and which may be accidentally touched by personnel in normal operation shall be guarded or insulated. Other high-temperature pipework shall be clearly marked.
14. If the ground is not level or can be subject to variable inclination, consult Atlas Copco.
15. The electrical connections shall correspond to the local codes. The units shall be grounded and protected against short circuits by fuses.

Operation

1. Air hoses shall be of correct size and suitable for the working pressure. Never use frayed, damaged or deteriorated hoses. Use only the correct type and size of hose end fittings and connections. When blowing through a hose or air line, ensure that the open end is held securely. A free end will whip and may cause injury. Make sure that a hose is fully depressurized before disconnecting it.

Never play with compressed air. Do not apply it to your skin or direct an air stream at people. Never use it to clean dirt from your clothes. When using it to clean down equipment, do so with extreme caution and use eye protection.

2. The compressor is not considered as capable of producing air of breathing quality. For breathing air quality, the compressed air must be adequately purified according to local legislation and standards.
3. Never operate the unit when there is a possibility of taking in flammable or toxic fumes.
4. Never operate the unit at pressures below or in excess of its limit ratings as indicated on the Principal Data sheet.
5. Keep all bodywork doors shut during operation. The doors may be opened for short periods only, e.g. to carry out checks. Wear ear protectors when opening a door.
6. People staying in environments or rooms where the sound pressure level reaches or exceeds 90 dB(A) shall wear ear protectors.
7. Periodically check that:
 - a. All guards are in place and securely fastened
 - b. All hoses and/or pipes inside the unit are in good condition, secure and not rubbing
 - c. There are no leaks
 - d. All fasteners are tight
 - e. All electrical leads are secure and in good order
 - f. Safety valves and other pressure-relief devices are not obstructed by dirt or paint
 - g. Air outlet valve and air net, i.e. pipes, couplings, manifolds, valves, hoses, etc. are in good repair, free of wear or abuse
8. If warm cooling air from compressors is used in air heating systems, e.g. to warm up a workroom, take precautions against air pollution and possible contamination of the breathing air.
9. Do not remove any of, or tamper with, the sound-damping material.

Maintenance

Maintenance and repair work shall only be carried out under supervision of someone qualified for the job.

1. Use only the correct tools for maintenance and repair work.
2. Use only genuine spare parts.
3. All maintenance work, other than routine attention, shall only be undertaken when the unit is stopped and the main power supply is

switched off. Take positive precaution to ensure that the unit cannot be started inadvertently.

In addition, a warning sign bearing a legend such as "**work in progress; do not start**" shall be attached to the starting equipment.

4. Before removing any pressurized component, effectively isolate the unit from all sources of pressure and relieve the entire system of pressure.
5. Never use flammable solvents or carbon tetrachloride for cleaning parts. Take safety precautions against toxic vapours of cleaning liquids.
6. Scrupulously observe cleanliness during maintenance and repair. Keep dirt away by covering the parts and exposed openings with a clean cloth, paper or tape.
7. Never weld or perform any operation involving heat near the oil system. Oil tanks must be completely purged, e.g. by steam-cleaning, before carrying out such operations.

Never weld on, or in any way modify, pressure vessels.

Whenever there is an indication or any suspicion that an internal part of a machine is overheated, the machine shall be stopped but **no inspection covers shall be opened** before sufficient cooling time has elapsed; this to avoid the risk of spontaneous ignition of the oil vapour when air is admitted.

Never use a light source with open flame for inspecting the interior of a machine, pressure vessel, etc.

8. Make sure that no tools, loose parts or rags are left in or on the unit.
9. Before clearing the unit for use after maintenance or overhaul, check that operating pressures, temperatures and time settings are correct and that the control and shut-down devices function correctly.
10. Every time the separator element is renewed, examine the discharge pipe and the inside of the oil separator vessel for carbon deposits; if excessive, the deposits should be removed.
11. Protect the motor, air filter, electrical and regulating components, etc. to prevent moisture from entering them, e.g. when steam-cleaning.
12. Make sure that all sound-damping material, e.g. on the bodywork and in the air inlet and outlet systems of the compressor, is in good condition. If damaged, replace it by genuine Atlas Copco material to prevent the sound pressure level from increasing.
13. Never use caustic solvents which can damage materials of the air net, e.g. polycarbonate bowls.
14. The following safety precautions are stressed when handling refrigerant R22, R12, etc.:
 - a. Never inhale refrigerant vapours. Check that the working area is adequately ventilated; if required, use breathing protection.
 - b. Always wear special gloves. In case of refrigerant contact with the skin, rinse the skin with water. If liquid refrigerant contacts the skin through clothing, **never tear off or remove** the latter; flush abundantly with fresh water over the clothing until all refrigerant is flushed away; then seek medical first aid.
 - c. Always wear safety glasses.

Note: With stationary machine units driven by an internal combustion engine, allowance has to be made for extra safety precautions, e.g. spark arrestors, fuelling care, etc. Consult Atlas Copco.

All responsibility for any damage or injury resulting from neglecting these precautions, or by non-observance of ordinary caution and due care required in handling, operating, maintenance or repair, even if not expressly mentioned in this book, will be disclaimed by Atlas Copco.

